

# HM210IT

## Level Converter, Direction Signal Decoder and programmable pulse divider



### Product features:

- Level Converter (RS-422, HTL Single Ended, HTL Differential, TTL and vice-versa)
- Implementation between the two types of representations for the direction of rotation (A/B 90 °, A/B Direction and vice versa)
- Adjustable division ratio of directional A / B pulses
- Adjustable division ratio for the Z pulse
- Reset of the Z divider by external input (defined setting)
- Zero setting of the A / B / Z divider by external input (defined Start / Stop)
- Z divider can also be used as an independent second divider
- Limit frequency up to 1 MHz, depending on the input format
- Push-pull outputs direct SPS control
- 9 to 30 VDC power supply

Version:	Description:
HM210IT_01a/CF/ Oct 2018	Version 1

## Table of Contents

<b>1. Safety Instructions and Responsibility .....</b>	<b>3</b>
1.1 General Safety Instructions .....	3
1.2 Use according to the intended purpose.....	3
1.3 Installation.....	4
1.4 Cleaning, Maintenance and Service Notes.....	4
<b>2. Introduction .....</b>	<b>5</b>
<b>3. Block diagram .....</b>	<b>5</b>
<b>4. Terminal Assignments and Connections.....</b>	<b>6</b>
<b>5. Programmable A/B Divider.....</b>	<b>8</b>
5.1 Level converter A/B Pulse (A/B Divider: All OFF).....	8
5.2 Input/Output Mode Converter (A/B Divider: All OFF) .....	8
5.3 Setting the A/B Divider (at A/B Dir to A/B 90°) .....	9
5.4 Setting the A/B divider (for all other modes) .....	10
5.5 Setting to zero the A/B divider with ZERO_A Signal .....	11
5.6 Informationen over the signal change A/B Dir .....	11
<b>6. Programmable Z Divider .....</b>	<b>12</b>
6.1 Pegel conversion Z Puls (Z Divider: all OFF).....	12
6.2 Setting the Z Divider .....	12
6.3 Location and width of the Z pulse.....	13
6.4 Independent Z Divider .....	14
6.5 Automatic generation of a Z pulse.....	15
6.6 Reset the Z divider with ZERO_Z Signal.....	15
<b>7. Error Output.....</b>	<b>15</b>
<b>8. Dimensions .....</b>	<b>16</b>
<b>9. Technical Specifications.....</b>	<b>17</b>

## 1. Safety Instructions and Responsibility

### 1.1 General Safety Instructions

This operation manual is a significant component of the unit and includes important rules and hints about the installation, function and usage. Non-observance can result in damage and/or impairment of the functions to the unit or the machine or even in injury to persons using the equipment!

**Please read the following instructions carefully before operating the device and observe all safety and warning instructions! Keep the manual for later use.**

A pertinent qualification of the respective staff is a fundamental requirement in order to use these manual. The unit must be installed, connected and put into operation by a qualified electrician.

**Liability exclusion:** The manufacturer is not liable for personal injury and/or damage to property and for consequential damage, due to incorrect handling, installation and operation. Further claims, due to errors in the operation manual as well as misinterpretations are excluded from liability.

In addition the manufacturer reserve the right to modify the hardware, software or operation manual at any time and without prior notice. Therefore, there might be minor differences between the unit and the descriptions in operation manual.

The raiser respectively positioner is exclusively responsible for the safety of the system and equipment where the unit will be integrated.

During installation or maintenance all general and also all country- and application-specific safety rules and standards must be observed.

If the device is used in processes, where a failure or faulty operation could damage the system or injure persons, appropriate precautions to avoid such consequences must be taken.

### 1.2 Use according to the intended purpose

The unit is intended exclusively for use in industrial machines, constructions and systems. Non-conforming usage does not correspond to the provisions and lies within the sole responsibility of the user. The manufacturer is not liable for damages which has arisen through unsuitable and improper use.

Please note that device may only be installed in proper form and used in a technically perfect condition - in accordance to the "Technical Specifications" (see chapter [8](#)). The device is not suitable for operation in explosion-proof areas or areas which are excluded by the EN 61010-1 standard.

### **1.3 Installation**

The device is only allowed to be installed and operated within the permissible temperature range. Please ensure an adequate ventilation and avoid all direct contact between the device and hot or aggressive gases and liquids.

Before installation or maintenance, the unit must be disconnected from all voltage-sources. Further it must be ensured that no danger can arise by touching the disconnected voltage-sources.

Devices which are supplied by AC-voltages, must be connected exclusively by switches, respectively circuit-breakers with the low voltage network. The switch or circuit-breaker must be placed as near as possible to the device and further indicated as separator.

Incoming as well as outgoing wires and wires for extra low voltages (ELV) must be separated from dangerous electrical cables (SELV circuits) by using a double resp. increased isolation.

All selected wires and isolations must be conform to the provided voltage- and temperature-ranges. Further all country- and application-specific standards, which are relevant for structure, form and quality of the wires, must be ensured. Indications about the permissible wire cross-sections for wiring are described in the Technical Specifications (see chapter [8](#)).

Before first start-up it must be ensured that all connections and wires are firmly seated and secured in the screw terminals. All (inclusively unused) terminals must be fastened by turning the relevant screws clockwise up to the stop.

Overvoltages at the connections must be limited to values in accordance to the overvoltage category II.

For placement, wiring, environmental conditions as well as shielding and earthing/grounding of the supply lines the general standards of industrial automation industry and the specific shielding instructions of the manufacturer are valid.

### **1.4 Cleaning, Maintenance and Service Notes**

To clean the front of the unit please use only a slightly damp (not wet!), soft cloth. For the rear no cleaning is necessary. For an unscheduled, individual cleaning of the rear the maintenance staff or assembler is self-responsible.

uring normal operation no maintenance is necessary. In case of unexpected problems, failures or malfunctions the device must be shipped for back to the manufacturer for checking, adjustment and reparation (if necessary). Unauthorized opening and repairing can have negative effects or failures to the protection-measures of the unit.

## 2. Introduction

The HM210IT is a universal interface using with incremental measuring systems. The device allows the solution of the following problems:

- Level conversion (RS-422, HTL single ended, HTL differential, TTL and vice versa)
- Division of two-track A / B pulses with adjustable ratio 1: 1 to 1: 2048
- Division of the Z pulse with adjustable ratio 1: 1 to 1: 256
- External HTL signals for various functions
- Implementation between the two types of representations for the direction of rotation (A/B 90 °, A/B Dir and vice versa, Division possible)

All settings are made on the DILL switches on the housing. The device consists of a compact housing with screw terminals and can be mounted on a DIN rail. Block diagram

## 3. Block diagram

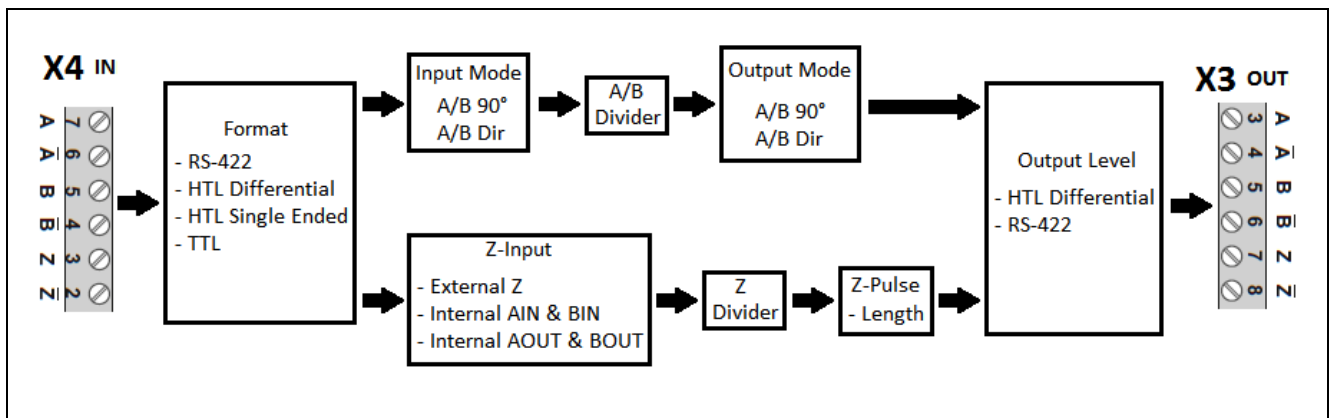

## 4. Terminal Assignments and Connections

The input pulses are connected to the screw terminals X4. The unused inputs must remain open (HTL Single Ended as opposed to HTL Differential), or possibly be completed (unused Z-track in RS-422 or HTL Differential format). On the X4 screw terminal 9, 8, an auxiliary voltage of + 5.5 V / 250 mA is available for the encoder supply.

Depending on the DIL switch setting, the pulses are available at the outputs of the screw terminal X3 in HTL or RS-422 format and are independent of the connected format. In the HTL setting, the height of the pulse level at the push-pull outputs corresponds to the input voltage at the supply input X1.

The Control HTL inputs (reset of the internal dividers) to X2 have PNP characteristics and must be switched against + to activate the function. The supply voltage is connected to X1.

It should be noted that all inputs and outputs refer to the same ground potential GND, which at the same time represents the negative pole of the device supply. At any time, the total transmission characteristics of encoder, external components and capacity of the cable must ensure proper signals at the input terminals of the unit, with respect to the levels, the shape and the phase displacement A/B.

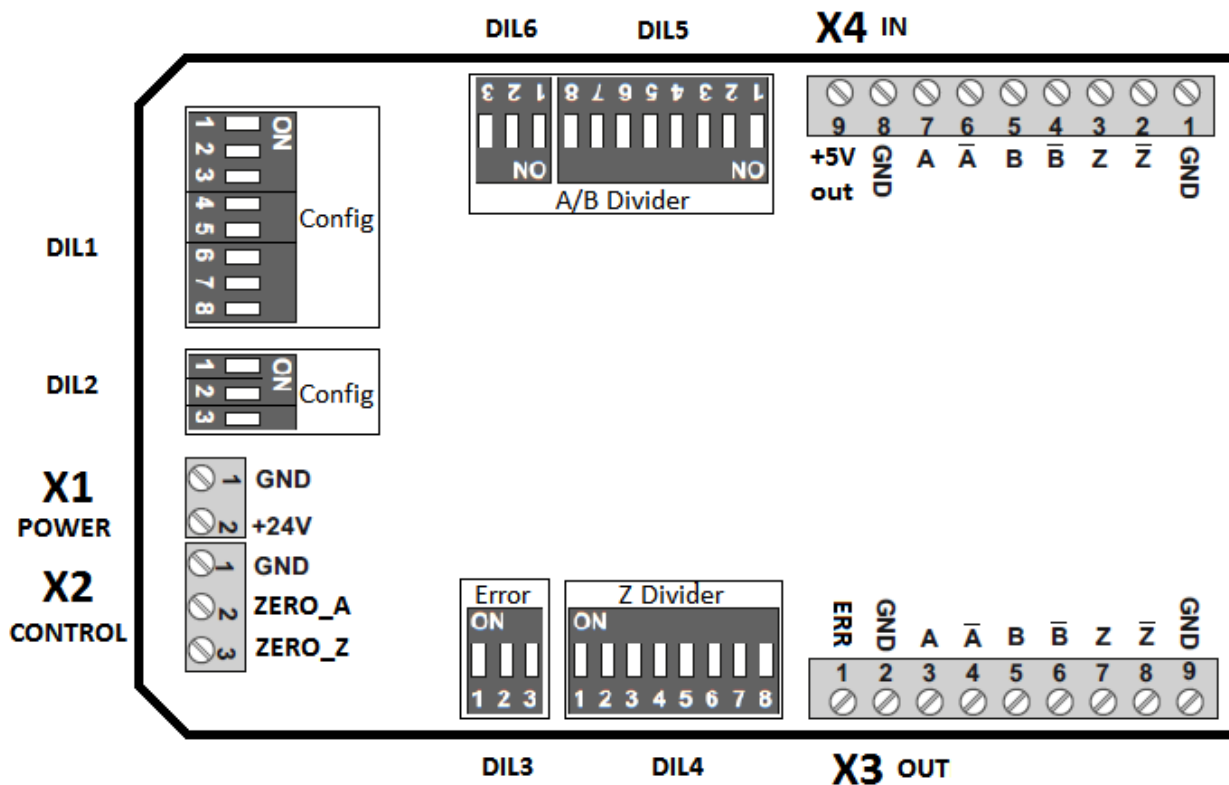

The green LED signals operational readiness (power switched on).

The yellow LED signals an input error. (RS-422 or HTL Differential only)

An HTL Error Signal (input error, only for RS-422 or HTL differential) is available on the X3 screw terminal 1. (Error = low)

**Basic settings:**

At the front DIL switches DIL1 and DIL2, some basic presets have to be made when commissioning. These determine the input/output mode, the input and output format, as well as settings of the Z Pulse.



Changes in the settings on the DIL switches will only be taken over by the device after the supply voltage has been switched on again!

Configuration								
DIL1 (Front 8-pole)								Function
1	2	3	4	5	6	7	8	
ON								Level for HTL Single Ended: $U_L < 10V / U_H > 14V$
OFF								Level for HTL Single Ended: $U < 5V / U > 9V$
	ON	ON						Input format: TTL
	ON	OFF						Input format: HTL Single Ended
	OFF	ON						Input format: RS-422
	OFF	OFF						Input format: HTL Differential
			ON	ON				Z-pulse length: 1 Z-Puls, independent of A / B
			OFF	ON				Z-pulse length: ynchronized with AOUT / BOUT
			ON	OFF				Z-pulse length: synchronized with AIN / BIN
			OFF	OFF				Z-pulse length: 1 Z-Puls, a depending on A/B
					ON			Input Mode : A/B Dir (Pulse / Direction)
					OFF			Input Mode : A/B 90°
						ON		Output Mode : A/B Dir (Pulse / Direction)
						OFF		Output Mode : A/B 90°
							ON	ZERO_A : Zero setting delayed, no errors
							OFF	ZERO_A : Zero setting immediately, error possible

Configuration			
DIL2 (Front 3-pole)			Function
1	2	3	
ON			Z-pulse: Generation of a Z-pulse from AIN & BIN, AOUT & BOUT
OFF			Z-pulse: Z input is used
	OFF		Test mode deactivated: OFF
		ON	Output format : HTL Differential, HTL Single Ended (UX1(2) – 2V)
		OFF	Output format: RS-422, TTL (5V)

## 5. Programmable A/B Divider

### 5.1. Level converter A/B Pulse (A/B Divider: All OFF)

If the A/B pulse have to be switched unchanged from the input to the output (no division, no change in length and position), then the DIL switch position listed below must be chosen. A level conversion is only possible if the input mode (A/B 90° or A/B dir) corresponds to the output mode. (DIL1/6 = DIL1/7).

Divider [A/B]											Comment
DIL5 (Left 8-pole)								DIL6 (Left 3-pole)			
1	2	3	4	5	6	7	8	1	2	3	
1	2	4	8	16	32	64	128	256	512	1024	← Binary value
OFF	OFF	OFF	OFF	OFF	OFF	OFF	OFF	OFF	OFF	OFF	AIN = AOUT, BIN = BOUT

### 5.2. Input/Output Mode Converter (A/B Divider: All OFF)

If input mode differs from output mode and in addition, the DIL switches DIL5 and DIL6 of the divider A/B are all set to OFF, the following signal characteristics are set up at the output.

#### Case 1: Input A/B 90°, Output A/B Dir

DIL1/6 = OFF, DIL1/7 = ON with A/B Divider setting: DIL5, 6 = all OFF

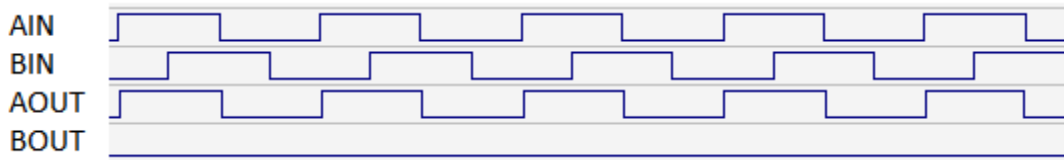

If the direction of the A/B 90° signal changes at the input, a change takes place at the BOUT output signal. (A/B dir). There is no division.

#### Case 2: Input A/B Dir, Output A/B 90°

DIL1/6 = ON, DIL1/7 = OFF with A/B Divider setting: DIL5, 6 = all OFF

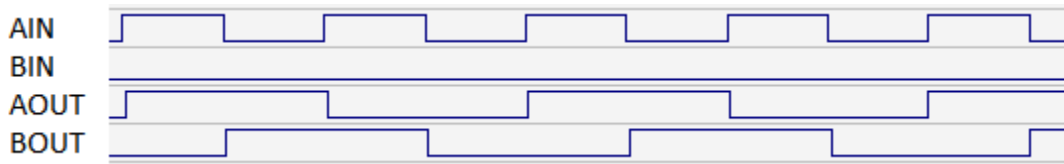

If a change takes place at the BIN input signal (A/B dir), the direction of the A/B 90° signal changes at the output. Here is a division 1:2, from the input in relation to the output.



**5.3. Setting the A/B Divider (at A/B Dir to A/B 90°)**

The division ratio for the A/B pulses is set at the DIL switches DIL5 and DIL6. The switch positions use a binary code like shown in the subsequent list. (DIL1/6 = ON, DIL1/7 = OFF).

Divider [A/B]											Comment
DIL5 (Left 8-pole)								DIL6 (Left 3-pole)			
1	2	3	4	5	6	7	8	1	2	3	
1	2	4	8	16	32	64	128	256	512	1024	← Binary value division => 1 : (Binary value +1) x2
ON	OFF	OFF	OFF	OFF	OFF	OFF	OFF	OFF	OFF	OFF	value 1 => 1 : 4
OFF	ON	OFF	OFF	OFF	OFF	OFF	OFF	OFF	OFF	OFF	value 2 => 1 : 6
ON	ON	OFF	OFF	OFF	OFF	OFF	OFF	OFF	OFF	OFF	value 3 => 1 : 8
OFF	OFF	ON	OFF	OFF	OFF	OFF	OFF	OFF	OFF	OFF	value 4 => 1 : 10
ON	OFF	ON	OFF	OFF	OFF	OFF	OFF	OFF	OFF	OFF	value 5 => 1 : 12
											...etc.
OFF	OFF	OFF	OFF	OFF	OFF	OFF	OFF	OFF	ON	OFF	1 : 1026
OFF	OFF	OFF	OFF	OFF	OFF	OFF	OFF	OFF	OFF	ON	1 : 2050
ON	ON	ON	ON	ON	ON	ON	ON	ON	ON	ON	1 : 4096

Example: Input A/B dir, output A/B 90° with A/B division 1:6 (setting DIL6, 5: OFF ON OFF)

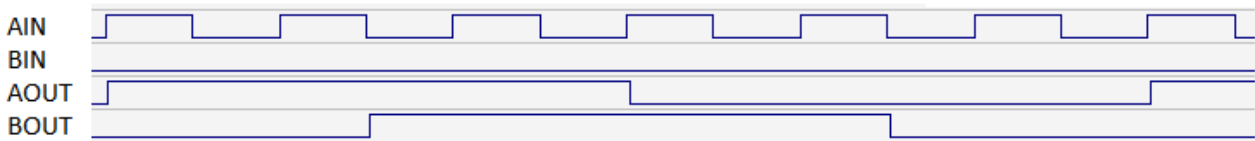

Division 1:2: See Input/Output Mode Conversion (A/B Divider: All OFF)

### 5.4. *Setting the A/B divider (for all other modes)*

The division ratio for the A/B pulses is set at the DIL switches DIL5 and DIL6. The switch positions use a binary code like shown in the subsequent list. (DIL1/6 = OFF, DIL1/7 = X).

Divider [A/B]											Comment
DIL5 (Lefts 8-pole)								DIL6 (Left 3-pole)			
1	2	3	4	5	6	7	8	1	2	3	
1	2	4	8	16	32	64	128	256	512	1024	← Binary value Division => 1 : Binary value +1
ON	OFF	OFF	OFF	OFF	OFF	OFF	OFF	OFF	OFF	OFF	value 1 => 1 : 2
OFF	ON	OFF	OFF	OFF	OFF	OFF	OFF	OFF	OFF	OFF	value 2 => 1 : 3
ON	ON	OFF	OFF	OFF	OFF	OFF	OFF	OFF	OFF	OFF	value 3 => 1 : 4
OFF	OFF	ON	OFF	OFF	OFF	OFF	OFF	OFF	OFF	OFF	value 4 => 1 : 5
ON	OFF	ON	OFF	OFF	OFF	OFF	OFF	OFF	OFF	OFF	value 5 => 1 : 6
OFF	ON	ON	OFF	OFF	OFF	OFF	OFF	OFF	OFF	OFF	value 6 => 1 : 7
ON	ON	ON	OFF	OFF	OFF	OFF	OFF	OFF	OFF	OFF	value 7 => 1 : 8
											...etc.
OFF	OFF	OFF	OFF	OFF	OFF	OFF	OFF	OFF	ON	OFF	1 : 513
OFF	OFF	OFF	OFF	OFF	OFF	OFF	OFF	OFF	OFF	ON	1 : 1025
ON	ON	ON	ON	ON	ON	ON	ON	ON	ON	ON	1 : 2048

Example: Input A/B 90°, output A/B 90° with A/B division 1:6 (setting DIL6, 5: OFF ON OFF)

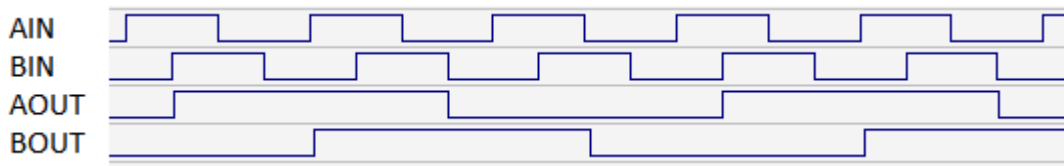

Example: Input A/B 90°, output A/B 90° with A/B division 1:3 (setting DIL6, 5: OFF ON OFF)

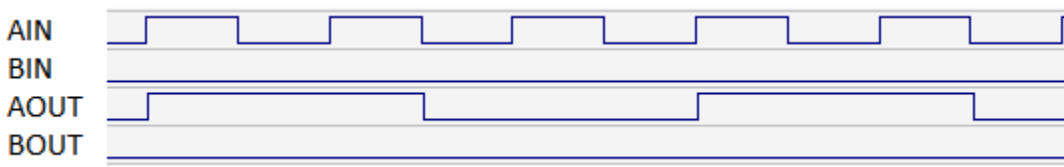

Example: Input A/B 90°, output A/B 90° with A/B division 1:3 (setting DIL6, 5: OFF ON OFF)

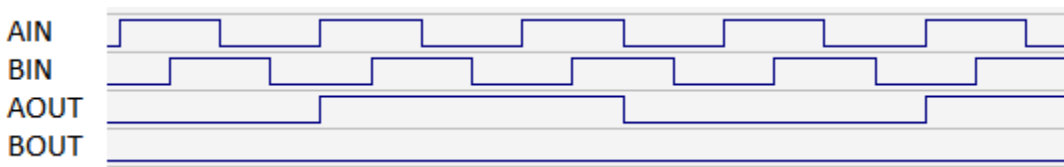

### 5.5. **Setting to zero the A/B divider with ZERO\_A Signal**

If the DIL switch DIL1/8 is set to OFF, the divider is reset immediately and remains as long as a high level at the ZERO\_A control input is applied. The A/B pulse can be trimmed by switching. A/B, 90 ° signals can cause illegal states when the ZERO\_A is switched on and off. In the case of A/B dir Signals, the reset is also done at the same time.

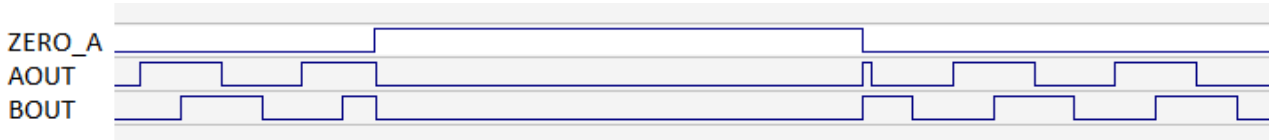

If the DIL switch DIL1/8 is set to ON, the divider will be reset in the zero phase of the output signals AOUT and BOUT and will remain as long as the signal is attached. This prevents the miscounting of subsequent circuits. This function can only be applied to A/B 90°, it is independent of the divider ratio.

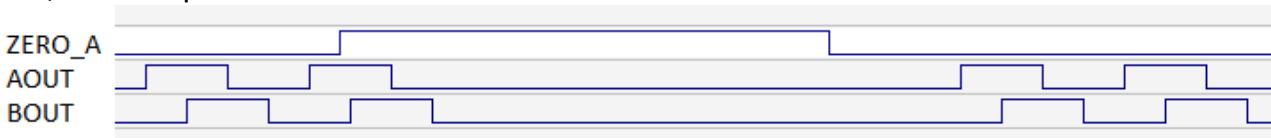

If there is a high signal at ZERO\_A the A/B divider is reset and has the starting state AOUT = BOUT = Low. The divider is in a defined state. Depending on the direction of the input signals, the next split A/B pulse appears immediately after the reset, or after the set division ratio. The length of the ZERO\_A pulse has to be greater than the period of frequency, than it can be switched off. This feature can be used for define start and stop. The Z track can be set to zero with the ZERO\_A input. The DIL switch DIL1/8 has been set to ON, A/B 90 ° output signals have been selected and the Z Pulse length has been synchronized to the output.

### 5.6. **Information over the signal change A/B Dir**

Signal changes from B (direction) should appear shortly before or latest at the same time as the A flank so that the change can be detected correctly.

## 6. Programmable Z Divider

### 6.1. Pegel conversion Z Puls (Z Divider: all OFF)

If the Z pulse have to be switched unchanged from the input to the output (no division, no change in length and position), then the DIL switch position listed below must be chosen.

Divider [Z]								Comment
DIL4 (right 8-pole)								
1	2	3	4	5	6	7	8	
1	2	4	8	16	32	64	128	← Binary value
OFF	OFF	OFF	OFF	OFF	OFF	OFF	OFF	ZIN = ZOUT (ZERO_Z = Low)

The output at the level conversion can be set to zero (ZOUT = Low) with the control input X2(3) ZERO\_Z = High.

The function is active as long as there is a high level at the control input. The Z pulse can be trimmed by switching.

### 6.2. Setting the Z Divider

The programming of the Z divider is subject to the same rules as the programming of the A/B divider.

Divider [Z]								Comment
DIL4 (right 8-pole)								
1	2	3	4	5	6	7	8	
1	2	4	8	16	32	64	128	← Binary value Divider => 1: Binary value +1
ON	OFF	OFF	OFF	OFF	OFF	OFF	OFF	1 : 2
OFF	ON	OFF	OFF	OFF	OFF	OFF	OFF	1 : 3
ON	ON	OFF	OFF	OFF	OFF	OFF	OFF	1 : 4
OFF	OFF	ON	ON	ON	ON	ON	ON	1 : 253
ON	OFF	ON	ON	ON	ON	ON	ON	1 : 254
OFF	ON	ON	ON	ON	ON	ON	ON	1 : 255
ON	ON	ON	ON	ON	ON	ON	ON	1 : 256

### 6.3. Location and width of the Z pulse

If the DIL switch DIL4 of the Z divider is completely set to OFF, the Z Pulse is forwarded from the input directly to the output (see pegel conversion Z Puls).

All pictures in this section assume that the A/B divider is set to 8. The Z Pulse is divided according to its divider (additionally DIL2/1 on OFF, ZIN is used, Z dividers not complete on OFF).

Depending on the length or location of the Z Pulses input and through the synchronization to the input or output signals, the Z pulse at the output can fluctuate around an input or output period (not with DIL1/5 = DIL1/4 = ON).

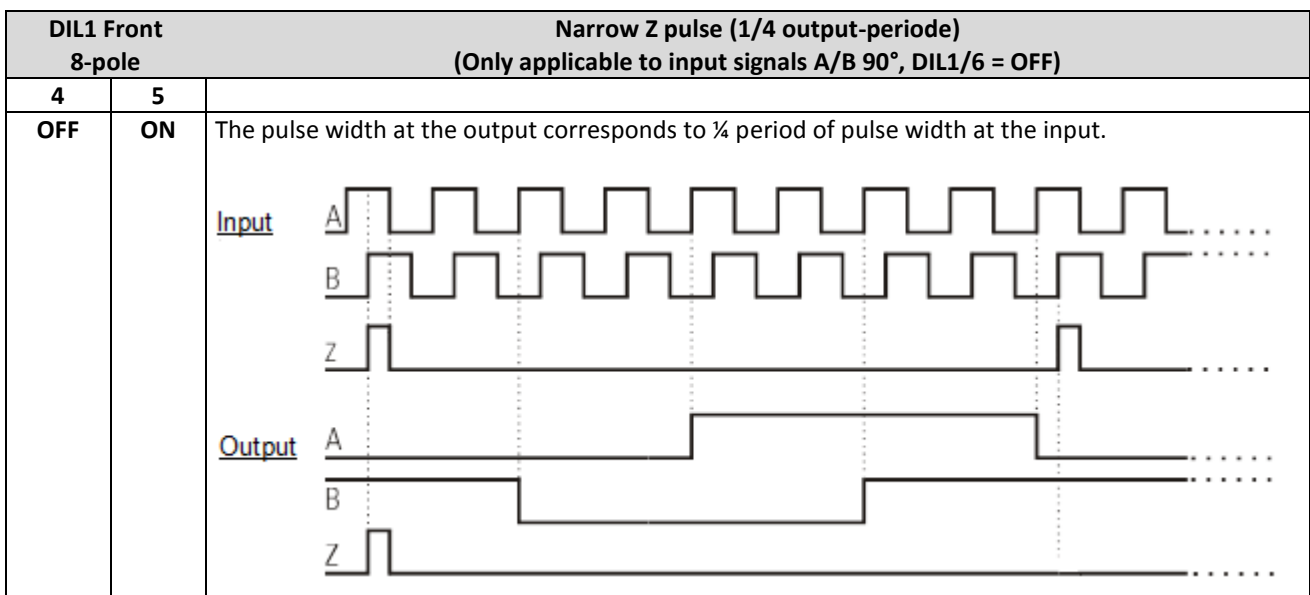
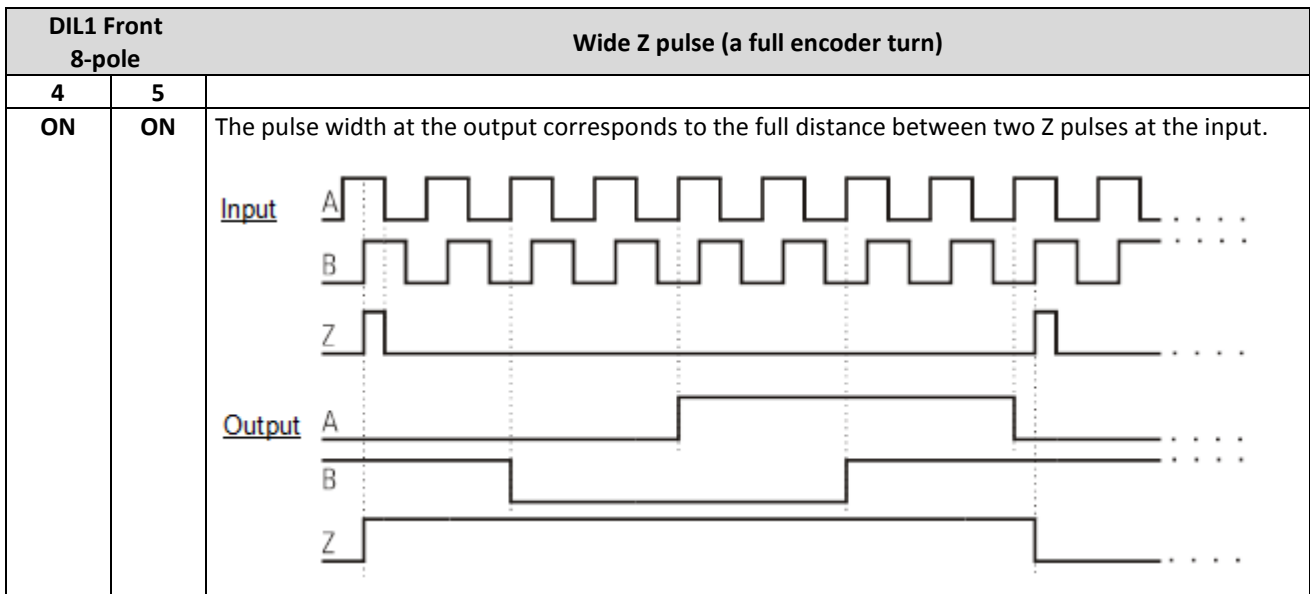

DIL1 Front 8-pole		Narrow Z pulse (1/4 output-period) (Only applicable to output signals A/B 90°, DIL1/7 = OFF)
4	5	
ON	OFF	<p>The pulse width at the output corresponds to ¼ period of pulse width at the output.</p>

In this operation mode, only division ratios may be used, which together with the A/B divisor deliver clear and completely results. A division with rest causes that the Z pulse at the output can fluctuate around an input or output period.

Example:

If at an encoder with 1000 pulses the A/B divider were set to 3 and at the same time the Z Pulse divider were set to 2, then the Z Pulse at the output would have to appear after 666,666 pulses, which is not physically possible.

### 6.4 Independent Z Divider

The Z divider works independently of the A/B track, the directional evaluation of the A/B signal does not affect the counting sequence (additionally DIL2/1 on OFF, ZIN is used, Z divider not completely set to OFF).

DIL1 Front 8-pole		Wide Z pulse (a full encoder turn)
4	5	
ON	ON	<p>The pulse width at the output corresponds to the full distance between two Z pulses at the input.</p>

### 6.5 Automatic generation of a Z pulse

If the DIL switch DIL2/1 is set to ON, a Z pulse can be automatically generated. The Z input is ineffective and does not need to be connected (Z divider not completely set on OFF).

DIL1 Front 8-pole		Narrow Z pulse (1/4 output- or input-period)
4	5	
OFF	ON	The Z pulse is generated from the input signal A/B. Each input period generates one count for the Z divider. The Z pulse width at the output corresponds to 1/4 period of the pulse width of the input signal A/B (Only applicable to input signals A/B 90°, DIL1/6 = OFF).
ON	OFF	The Z pulse is generated from the output signal A/B. Each output period generates one count for the Z divider. The Z pulse width at the output corresponds to 1/4 period of the pulse width of the output signal A/B (Only applicable to output signals A/B 90°, DIL1/7 = OFF).

### 6.6 Reset the Z divider with ZERO\_Z Signal

The Z divider can be reset by applying a high signal to the control input ZERO\_Z. The reset will act immediately and as long as the signal is applied. Depending on the direction of the A/B track, the next Z pulse appears immediately after the reset or according to the set division ratio (not at the independent Z divider). The reset of the Z divider can also be performed in case of automatic generation of the Z pulse. By setting the Z-divider = all OFF, the setting of the ZERO\_Z input causes an immediate zero setting of the output ZOUT (see level conversion Z pulse). Note the special case in which the ZERO\_A signal can also set the Z output to zero (see Setting to zero of the A/B divider with ZERO\_A signal)

## 7 Error Output

An HTL error signal is available on the X3 screw terminal 1. (Error = Low). The error (short circuit or line break) is triggered by the input lines A, /A, B, /B or Z, /Z (Test mode OFF, DIL2/2 = OFF). The corresponding channel can be selected with the DIL switch DIL3 (right, 3-pole). If the DIL switch DIL3/1 is set to OFF, no errors are evaluated on the A, /A line, the DIL switch DIL3/2 refers to the line B, /B and the DIL switch DIL3/3 to the line Z, /Z. An error can only be detected in RS-422 or HTL differential format, all other formats do not trigger an error.

## 8 Dimensions

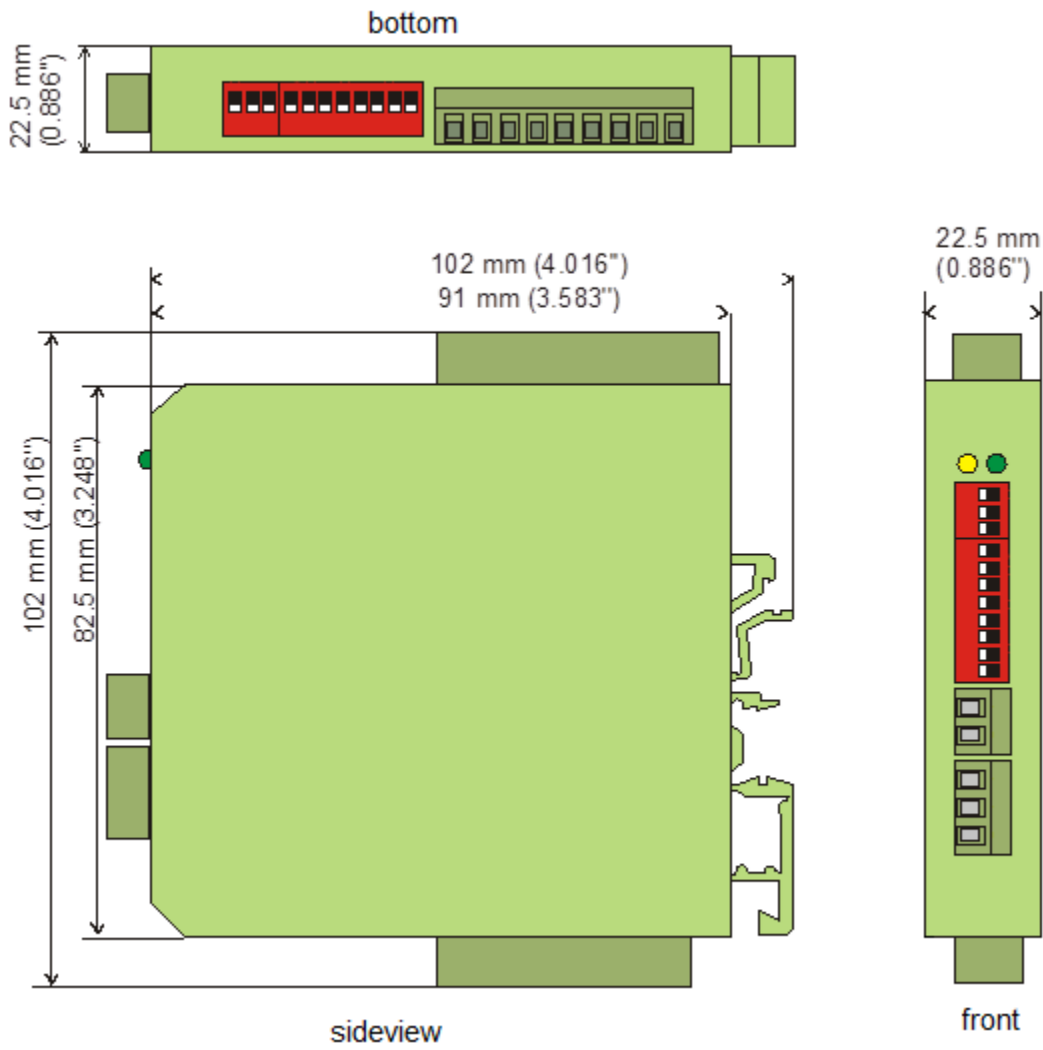



## 9. Technical Specifications

Technical Specifications		
<b>Power supply:</b>	Input voltage:	9 ... 30 VDC
	Protection circuit:	reverse polarity protection
	Ripple:	≤ 10 %
	Consumption:	approx. 40 mA (at 9 V, unloaded) approx. 30 mA (at 30 V, unloaded)
	Connections:	screw terminal, 1.5 mm <sup>2</sup> / AWG 16
<b>Sensor supply:</b>	Output voltage:	+ 5,5 VDC +/- 5 %
	Output current:	max. 250 mA
	Connections:	screw terminal, 1.5 mm <sup>2</sup> / AWG 16
<b>Control input:</b>	Signal levels:	HTL, U <sub>L</sub> < 5V/ U <sub>H</sub> > 9V
	Input current:	approx 3 mA
	Frequency:	20 kHz, 50 us
	Connections:	screw terminal, 1.5 mm <sup>2</sup> / AWG 16
<b>Incremental inputs:</b>	Signal level:	RS422, differential voltage > 1 V HTL Differential, differential voltage > 2 V HTL Single Ended, U <sub>L</sub> < 10V/ U <sub>H</sub> > 14V HTL Single Ended, U <sub>L</sub> < 5V/ U <sub>H</sub> > 9V TTL, U <sub>L</sub> < 0.7V/ U <sub>H</sub> > 2.2V
	Traces:	A, B, Z (HTL Single Ended, TTL) A, /A, B, /B, Z, /Z (RS422, HTL Differential )
	Frequency:	RS422, 1 MHz HTL Differential, 1MHz HTL Single Ended, 350kHz TTL, 350kHz
	Connections:	screw terminal, 1.5 mm <sup>2</sup> / AWG 16
<b>Inkremental-Ausgang:</b>	Signal level:	8 ... 29 V bei HTL (Depending on supply voltage) 5 V at RS422
	Traces:	A, /A, B, /B, Z, /Z
	Delay:	Approx. 600ns
	Output current:	max. 20 mA / Push-Pull
	Connections:	screw terminal, 1.5 mm <sup>2</sup> / AWG 16
<b>Housing:</b>	Material:	plastic
	Mounting:	35 mm top hat rail (according to EN 60715)
	Dimensions (w x h x d):	22,5 x 102 x 102 mm / 0,886 x 4,016 x 4,016"
	Protection class:	IP20
	Weight:	approx. 100 g
<b>Ambient temperature:</b>	Operation:	0 °C ... +60 °C / +32 ... +140 °F (not condensing)
	Storage:	-25 °C ... +70 °C / -13 ... +158 °F (not condensing)
<b>Failure rate:</b>	MTBF in years:	109,3 (long-term usage at 60 °C / 140 °F )
<b>Conformity &amp; standards:</b>	EMC 2004/108/EC:	EN 61000-6-(2-4)
	2011/65/EU:	RoHS